

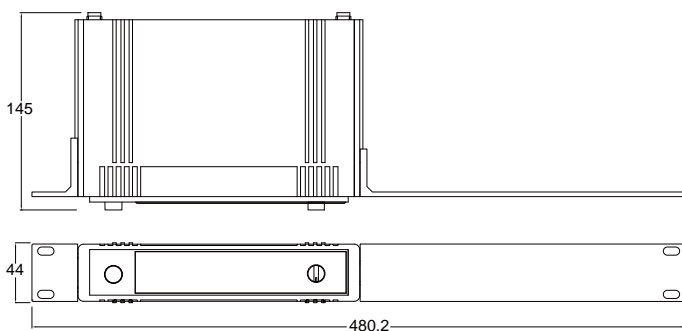

EX-100 제품사양

주파수대역	925MHz ~ 937.5MHz (UHF)
발전방식	PLL Synthesized
채널수	32채널 (1그룹:16채널, 2그룹:16채널)
주파수 응답대역	50Hz~17KHz
신호대잡음비 (S/N)	110dB 이상
의율 (T.H.D)	0.1%이하
수신감도	-100dBm
톤 주파수	Dual tone code 방식 (특허)
출력 레벨	Balanced -11dBm / 600Ω Unbalanced -11dBm / 10KΩ
아웃풋 타입	Balanced XLR, Unbalanced 1/4"
안테나 타입	헬리컬(Helical) 타입
사용 전원	DC 12V 1A 어댑터
크기 (WxDxH)	212 x 145 x 44mm (Half Rack Size)
무게	560g
송신기타입	EX-100B, EX-100H

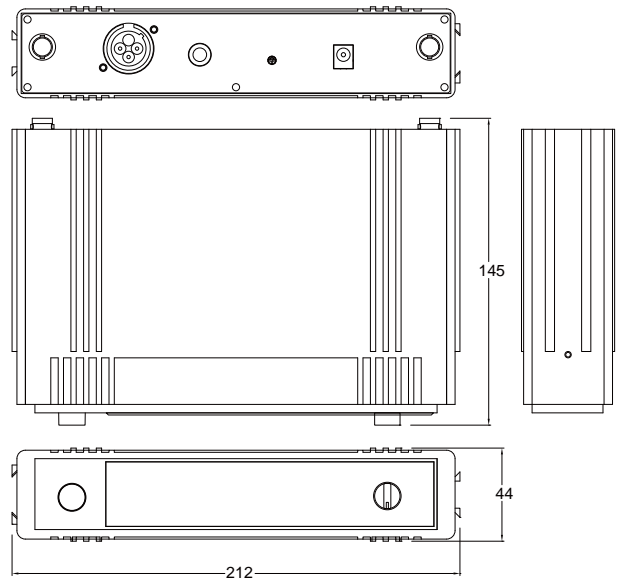

(1채널 랙 장착)

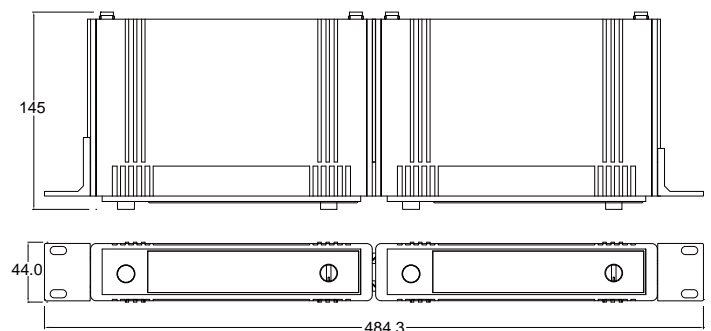

(2채널 랙 장착)